

An Overview of the Enhanced Modified Faraday Cup (EMFC) Electron Beam Power Density Distribution Diagnostic

J. W. Elmer*, T. A. Palmer** and A. T. Teruya*

*Lawrence Livermore National Laboratory

**The Pennsylvania State University

The Enhanced Modified Faraday Cup (EMFC) electron beam diagnostic tool was developed to measure the power distribution of high power density electron beams. Unlike existing qualitative methods based on the transfer of machine settings, the EMFC uses quantitative measurements of specific beam properties to determine the beam's power density distribution for both sharp and defocused beams. Operationally, the EMFC probes the electron beam using a series of radial slits machined into a circular disk. As the beam is rapidly circled over the slits, beam profile data are acquired from multiple angles. Computed tomography algorithms are then used to reconstruct the beam for rapid analysis of the beam. Based on the reconstruction, the important beam properties, including measures of the beam width and peak power density are determined and recorded for quality control purposes. This paper presents an overview of the EMFC device and its beam characterization techniques, highlighting applications in weld development, weld transfer between different machines and facilities, and quality control in production.

Introduction

Quality control in electron beam (EB) welding is similar to that of other welding processes, where the primary goal is to consistently produce defect free and structurally sound welds by controlling the essential weld variables. Existing process controls in electron beam welding are typically directed at controlling the essential machine settings, which include the accelerating voltage, beam current, focus coil current, vacuum level, travel speed, and work distance [1]. A primary assumption in these existing process control techniques is that the machine settings are highly accurate and reproducible and have a direct correlation with the resulting beam characteristics [2]. Each of these machine settings is quantifiable and can be tightly controlled before and during the welding process, except for the focus conditions of the EB welder. The focus of the beam is traditionally set with respect to an operator-determined 'sharp focus' setting. However, the actual beam characteristics, defined in terms of specific quantifiable parameters, such as the beam diameter and power density distribution at this 'sharp focus' setting can vary significantly with different operators, machines, and operating conditions.

Early methods for quantifying sharp focus used carefully machined stair-stepped shaped plates with steps of different heights relative to the beam propagation axis [3]. Welds were made along these plates, and as the beam passes over them, the widths and depths of the resulting welds changes. The sharp focus location for the electron beam was defined as the position on the plate where the width of the melted material is a minimum. These experiments are expensive to perform and provided minimal information about the beam itself, but were useful in determining the sharp focus condition for a particular machine and set of welding conditions. Clearly, new

methods were desired for measuring beam properties that were more economical, and that could directly measure actual beam properties.

The use of diagnostic tools for direct probing of beam characteristics has been evolving over the past couple of decades with the development of several diagnostic tools [4, 5]. These beam probing techniques are primarily based on modifications to a traditional Faraday Cup. They utilize direct measurements of the electron beam current to obtain a profile of the energy distribution as the beam passes over an edge, slit, or pinhole, or alternatively by intercepting the beam with small diameter electrically conductive rotating wires. Recent advances in diagnostics are favoring pinhole and slit methods over rotating wires, and several commercial systems have been developed along these lines. The pinhole method [6], a pinhole plus a single slit (Diabeam) [7-9], a two slit method specifically designed for high power beam [4, 10], and multiple slit methods [11-14] have been developed and tested. One goal of these diagnostics is to be able to characterize high power electron beams in much the same way as laser beams have been characterized for decades [15]. Measurements of beam divergence as well as beam size so that the beam parameter product (BPP) can be used to directly compare beams made on different machines that have different electron guns, cathodes, optics, and work distances.

Recently, the Enhanced Modified Faraday Cup (EMFC) method has been used to characterize electron beams on different machines [16], transfer electron beam welds between different machines and different facilities [17], provide quality and process control in production [18], and compare the properties of high voltage and low voltage electron beam machines [19]. This paper summarizes some of these applications of the EMFC to illustrate how modern diagnostics are becoming a necessary tool for many

applications rather than just a research and development curiosity.

Operation of the EMFC Diagnostic

The EMFC diagnostic and its operation are discussed in several previous references [11-14], while specific applications are further discussed in references [16-19]. These publications cover the EMFC method in detail, so only a brief introduction will be presented.

The EMFC device is essentially a very accurate Faraday cup that has a number of unique features that allow it to measure the power density distribution of high power density electron beams. Figure 1 shows a schematic of the EMFC, where the top central feature is a tungsten disk containing 17 radially oriented narrow slits with widths of 0.1mm. During operation, the deflection coils of the EB welder are used to circle the beam in a path over the tungsten slit disk. As the beam passes over each slit, a portion of the beam's current is captured as it passes through the slit and enters into the Faraday cup. Using a fast sampling analog-to-digital (A/D) converter, the beam current is integrated by the slit to provide a profile of the beam at the given angle that the beam intercepts a given slit. The multiple slits, oriented radially around the circle, provide 17 different profiles of the beam. With one revolution around the slit disk, a single waveform containing the 17 profiles is captured and converted into a sinogram that can be used for computed tomographic (CT) reconstruction of the power density distribution of the beam [11-12]. The CT process is performed on a single computer that both captures and reconstructs the beam in approximately one minute. The present version of the EMFC system is designed to handle high voltage beams of approximately 1 kW in power, but can be scaled up to higher powers if required.

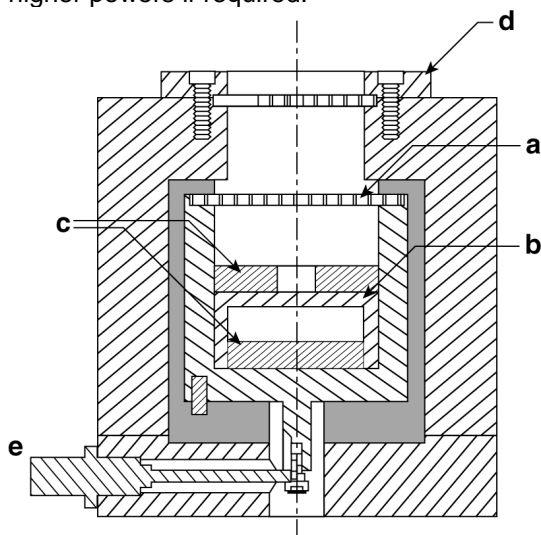

Figure 1: Schematic cross section of the EMFC diagnostic: a. internal slit disk made of copper, b. internal beam trap, c. graphite beam interceptors, d. tungsten slit disk clamp, and e. BNC connector.

After acquiring the data, CT reconstruction is employed to produce a full description of the power

density distribution at the plane of the tungsten slit disk. The description includes the peak power density of the beam and two spatial distribution parameters. The first distribution parameter is the full width of the beam at 50% of its peak power density (FWHM). The second parameter is the full width of the beam measured at $1/e^2$ (13.5%) of its peak power density (FW e^2). This parameter is considered to be a suitable representation of the beam diameter, much in the same way that laser beams diameters are measured and recorded. Since the cross section of the measured beam is not always circular, the area of the beam at each of these two points in the reconstructed power density distribution curve is measured, and the diameter of a circle having the same area is used to represent FWHM and the beam diameter values. These approximations are suitable for most beams with generally circular cross sections, such as the Gaussian-like distributions typically found near the sharp focus setting. In addition, for non-circular beams that often have an elliptical shape, the major and minor axes of the beam are calculated and reported so that the orientation of the beam with respect to the welding direction is known.

Non-circular and Irregular Beam Measurements

Not all electron beams are circular in shape, and this effect becomes more extreme as the beam becomes more defocused. Astigmatism caused by poor beam alignment, non-centered cathodes, and/or improperly peaked cathodes can all contribute to irregular shaped beams. In addition, cathodes are not always circular, such as square ribbon filaments or wire-shaped hairpin filaments [12]. Since single angle methods are not able to measure any asymmetry of the beam, pinhole or multiple slit/angle techniques are required. The EMFC, with 17 slits and computed tomography, was designed specifically to deal with irregularly shaped beams [11-14]. Two examples of irregular beam shapes are shown in Fig 2.

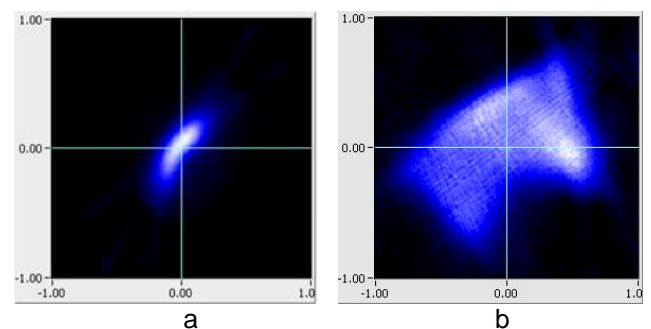

Figure 2: EMFC CT reconstruction of defocused beams showing a) elliptical, and b) highly irregular behaviour; axes in mm.

Figure 2a shows a defocused beam on LLNL EB welder #605 for a 100 kV, 5.6 mA beam with a +15 defocus, created from a ribbon filament (R-167R) with a 1 mm square emitting surface. The beam is elliptical in shape and has a peak power density of

3.61 kW/mm². Using the EMFC it was shown that the beam has a FWe2 across the major axis of 0.91 mm, FWe2 across the minor axis of 0.38 mm, an axis angle of 53.4 deg, and an average FWe2 of 0.62 mm. When welding with elongated beams, the weld geometry may vary with the welding angle. This is because the beam is narrower and more intense when travelling parallel to its major axis, and this effect can be used to an advantage if the beam is properly characterized. A more extreme example of a non-circular beam is shown in Fig 2b for a 20 mA, 120 kV beam defocused +33 on EB #605, showing highly irregular behaviour.

EB Mapping and Beam Matching using the EMFC

Controlling the electron beam spot size is critical to making high quality welds, because small changes in the beam diameter can impact the resulting weld geometry. For a given beam current, the minimum beam size is most strongly influenced by the work distance and the accelerating voltage of the beam. Therefore, for any given machine it is important to know how changes in these parameters affect the beam properties.

One example of how the EMFC can be used to map the beam size as a function of work distance and focus setting is summarized in Fig. 3 [16]. This figure illustrates the typical application of the EMFC, where the beam properties are measured as a function of the focus setting in order to determine the minimum beam size and the peak power density. Here, the data are plotted as a function of "relative machine focus setting", which is the difference in the focus setting, above (positive) or below (negative), between the actual focus setting and the focus setting where the beam is at its minimum size. Figure 3a plots the peak power density for five different work distances for a 100 kV, 10 mA beam. The work distance varies from 127 mm to 457 mm below the heat shield on the top inside wall of the EB welder, which is the maximum working range for this welder, which is a Hamilton Standard 150 kV, 15mA machine (S/N #175). The peak power density of the most intense beam is shown to vary by more than 4X (from ~7.8 to ~35 kW/mm²) over this working distance range. Similar plots are shown for the FWHM (Fig. 3b) and beam diameter FWe2 (Fig. 3c). The inverse square relationship between beam size and power density are apparent as the beam size reaches a minimum where the power density reaches its maximum. Correspondingly, the smallest beams are present at the shortest work distances. Over the working distances studied, the FWHM (0.16 to 0.34 mm) and FWe2 (0.26 to 0.56 mm) vary by approximately a factor of 2.

It is important to note that not all machines exhibit the same behavior with changes in the work distance. Figure 4 plots the minimum Fwe2 values for EB welder #175 from Fig 3c plus one additional data

point, versus working distance (solid circles). These data are compared to similar data from a different Hamilton Standard 150 kV, 50 mA welder, (S/N #605). This plot shows that in both cases the beams grow linearly in size with work distance, but that the slopes and intercepts are different for the two machines [16]. Extrapolation of the data back to zero, gives the approximate cross over location of the beam in the upper column, and when fully analyzed, this data can be used to estimate the diameter of the beam at cross over, and the relationship for the beam size as a function of work distance for a given beam current and voltage [16].

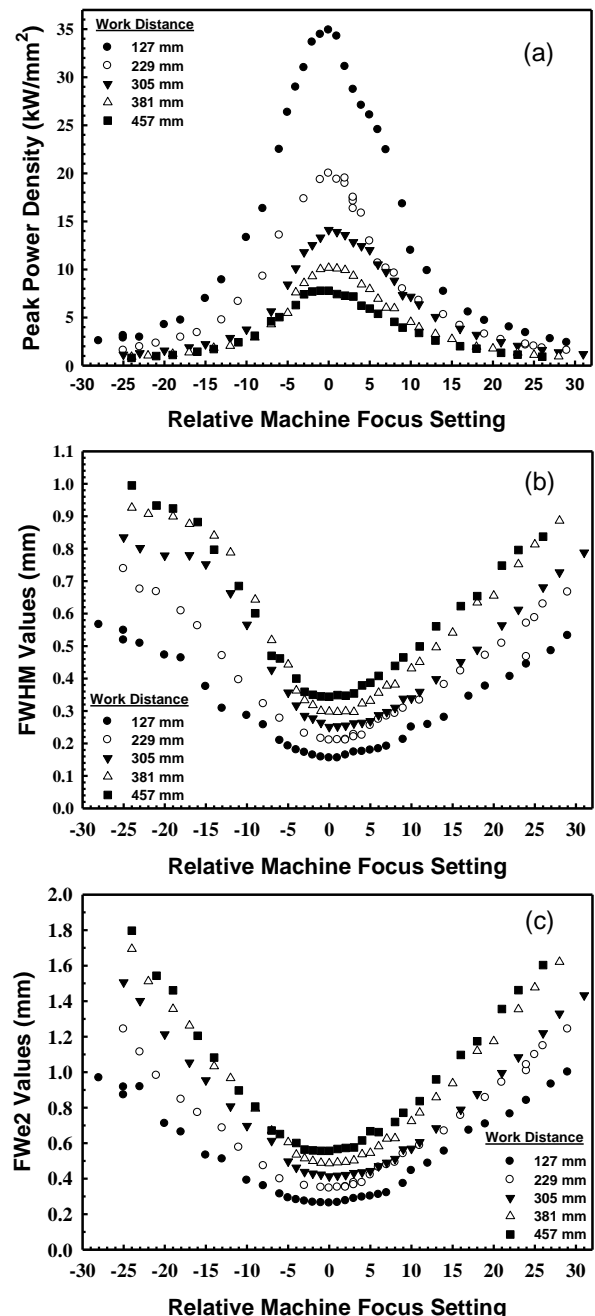

Figure 3: EMFC measures of (a) peak power density, (b) FWHM, and (c) FWe2 with changes in the focus setting for 100 kV, 10 mA beams for five different work distances on EB #175.

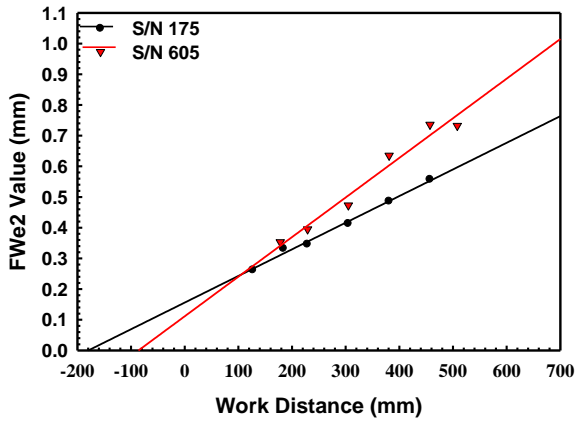

Figure 4: Comparisons between FWe2 values measured at sharp focus for two different welders as a function of work distance (100 kV, 10 mA).

From relationships like those presented in Fig. 4, it is possible to create beams of equal properties on two different machines by adjusting the working distances accordingly. One case in point is the transfer of beams between two machines, where one machine produces an unachievable sharp focused beam than the other.

Such a case is discussed in ref [17] for the transfer of a weld between two facilities with significantly different sized chambers and correspondingly different working distances. The LLNL welder #175 was used to develop a weld at a nominal work distance of 210 mm, for production at the Y-12 facility in a newer electron beam machine with a fixed work distance of 457 mm. Prior to making each weld, both machines were mapped at the desired beam conditions (100 kV, 10 mA), as summarized in Fig. 5.

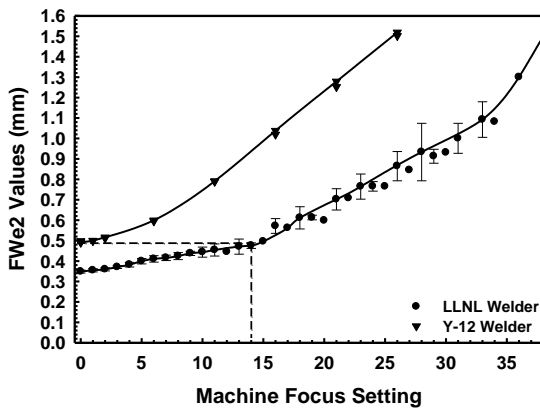

Figure 5: EMFC measures of the FWe2 values for the LLNL welder at 210mm work distance and the Y-12 welder at 457 mm work distance (100 kV, 10 mA).

It is clear from Fig. 5 that the minimum beam size on the LLNL welder (FWe2=0.35 mm) could not be achieved on the Y-12 welder since its minimum beam size (FWe2) was 0.47 mm. In order to match the two beams, the LLNL welder needed to be defocused by 14 mA, as indicated in Fig. 5. With additional

parameterization and comparisons, the final parameters required a +11 defocus on the LLNL machine for a targeted peak power density of 11.0 kW/mm², a FWHM of 0.212 mm, and a FWe2 of 0.34 mm. The resulting welds are shown in Fig. 6 which compares the cross sections in 304L stainless steel (SS) made on each welder using the EMFC to measure and control the beam parameters.

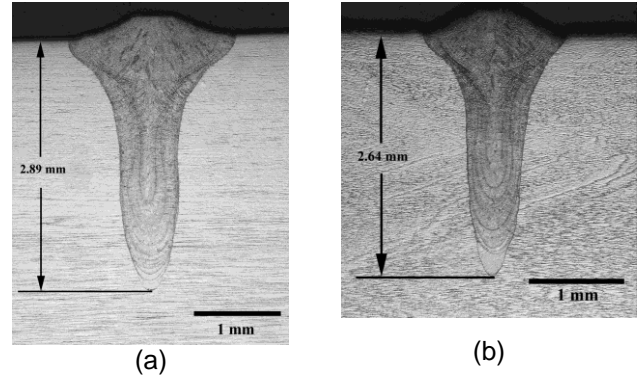

Figure 6: Keyhole weld cross sections in 304L SS produced by: (a) LLNL at a work distance of 210 mm with +11 defocus, and (b) Y-12 at a work distance of 457 mm and sharp focus (100 kV, 10 mA, 17 mm/s).

Quality Control using the EMFC

Once the welding parameters for a given process have been developed, it is important to maintain these parameters throughout the production run. Without a quantitative measure of the beam parameters provided by diagnostics, there is no good way to control the parameters or the process. To illustrate how the focus can vary in production, Fig. 7 compares the difference in focus setting between an experienced operator, and the EMFC for a 75 kV, 6.5 mA beam on welder #605 [18]. These data were acquired over a period of several months, where the operator's sharp focus setting initially varied by roughly ± 5 mA relative to the EMFC measured sharp focus value. With time, the operator began to improve his accuracy (welds 27 and higher), by being able to anticipate the EMFC measurement based on previous experience, and narrowed the range to roughly ± 2 mA of relative focus.

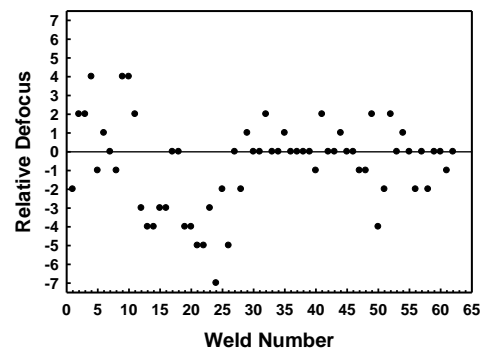

Figure 7: Variation of the relative focus difference between the operator and EMFC (solid line).

Throughout the production run of 87 welds, the beam properties were analyzed over a period of about 6 months with multiple cathode changes [18]. The actual welds were made with a +5 mA defocus relative to the EMFC sharp value setting, and beam profile data was maintained throughout the production run. Fig. 8 shows one of the results from this study where FWe2 is plotted for each of the production welds and compared to a $\pm 5\%$ tolerance band [18]. The initial 30 welds were made by using the EMFC to find sharp focus, and then adjusting the focus a fixed amount of +5mA as per the weld procedure. Beam profile statistics show that occasionally the beam was coming close to falling out of the $\pm 5\%$ tolerance band on beam diameter, and a change was made to the procedure. The change consisted of allowing the defocus amount to vary by a small amount (flexible) while using the EMFC to maintain the peak power density, FWHM and FWe2 within a tighter range. These data are shown in Fig. 8 for welds 31-87, where, clearly, the variation has been reduced, to $\pm 2.5\%$ on FWe2. Additional details can be found in [18], but it is clear that with the proper procedures, the EMFC can be used to tightly control the beam properties.

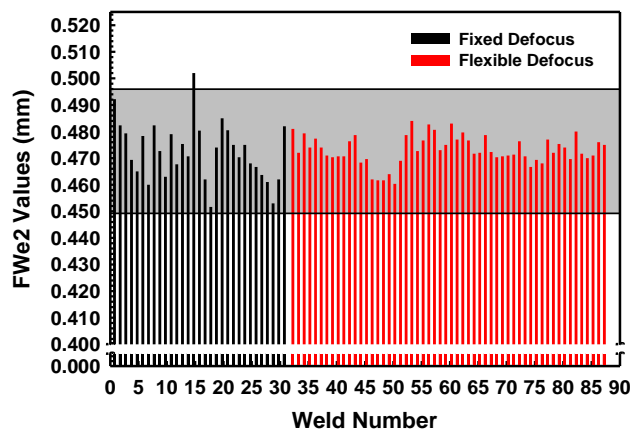

Figure 8: FWe2 values for beams comparing the fixed EMFC defocus (welds 1-30) with the flexible defocus EMFC method (welds 31-87). The shaded band indicates a $\pm 5\%$ tolerance band.

Weld Consistency using the EMFC

A final example is presented where a defocused weld was required in a stainless steel component, that required tight control over the weld geometry and penetration. The weld was highly defocused at approximately +30 mA, and operated in a conduction rather than keyhole mode. The developed weld parameters were for a 110kV, 5.5 mA beam moving at 60 ipm, targeting a 1.0 mm diameter beam with a 0.5 mm FWHM and a peak power density of 1.5 kW. Six welds were made over a period of time with separate weld setups and pumpdowns. The resulting weld cross sections are shown in Fig.9, indicating very similar weld pool shapes with penetration to the weld step and minimal penetration past the weld step. The EMFC measurement summary for each of the welds is

presented in Table 1 along with statistics of the resulting beam depths and widths. Note that the amount of defocus required to maintain the beam reduced from 32 to 29 mA throughout this period, as the beam intensity appeared to degrade with time. The result is that the beam FWHM, FWe2 and peak power density were maintained within 2.5% on average, and that the weld penetration was held to within 7% for the 6 welds.

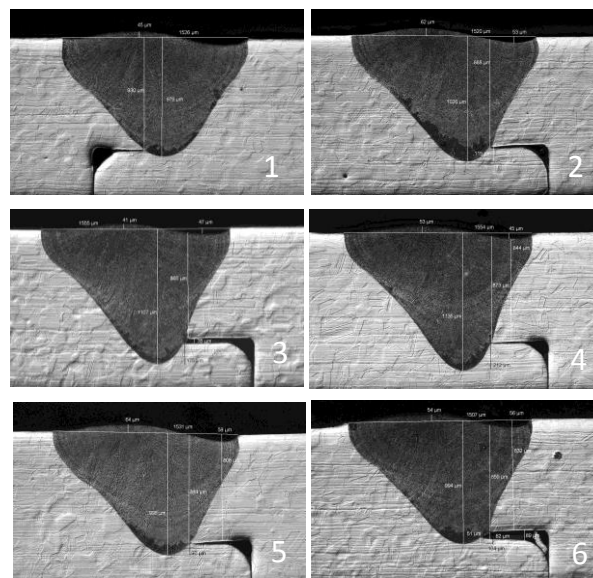

Figure 9: Metallographic cross sections for the six individual electron beam welds in stainless steel.

Table 1: EMFC measurements of the beams and six stainless steel weld zone geometries.

Weld	Focus Setting (mA)	Beam Peak PD (W/mm ²)	Beam FWHM (mm)	Beam Diameter (mm)	Weld Depth (mm)	Weld Top Width (mm)
1	762 (+32)	1500	0.49	0.98	0.98	1.53
2	760 (+30)	1550	0.51	0.97	1.03	1.52
3	760 (+30)	1510	0.51	0.98	1.11	1.56
4	759 (+29)	1480	0.54	1.00	1.14	1.55
5	759 (+29)	1445	0.52	1.01	1.00	1.53
6	759 (+29)	1470	0.51	0.99	0.99	1.51
Avg. /std	759.8 /1.2	1493 /36.2	0.51/0.02	0.99 /0.02	1.04 /0.07	1.53 /0.02

Conclusion

The EMFC diagnostic was developed to measure the properties of high power density beams in both the sharp and defocused conditions. It was specifically developed to analyze circular, elongated, and irregular beam shapes. Data from the EMFC have also been successfully applied to weld development, allowing beams to be matched on different machines, the facilitation of weld parameter transfer between facilities, and quality control in production not possible without diagnostics. With the correct procedures, the EMFC can be used to control the beam size to better than 3%, providing enhanced quality control over the EB welding process.

Acknowledgments

This work performed under the auspices of the U.S. Department of Energy by Lawrence Livermore National Laboratory under Contract DE-AC52-07NA27344. This document was prepared as an account of work sponsored by an agency of the United States government. Neither the United States government nor Lawrence Livermore National Security, LLC, nor any of their employees makes any warranty, expressed or implied, or assumes any legal liability or responsibility for the accuracy, completeness, or usefulness of any information, apparatus, product, or process disclosed, or represents that its use would not infringe privately owned rights. Reference herein to any specific commercial product, process, or service by trade name, trademark, manufacturer, or otherwise does not necessarily constitute or imply its endorsement, recommendation, or favoring by the United States government or Lawrence Livermore National Security, LLC. The views and opinions of authors expressed herein do not necessarily state or reflect those of the United States government or Lawrence Livermore National Security, LLC, and shall not be used for advertising or product endorsement purposes

References

1. 'Recommended Practices for Electron Beam Welding', 2004, AWS C7.1M/C7.1:2004, Miami, FL, American Welding Society.
2. Ander P.I. and Scheffels W., "Process Control for Electron Beam Welding", *Welding in the World*, 1992, **30**(5/6), 138-144.
3. Arata Y., "Evaluation of Beam Characteristics by the AB Test Method", in *Plasma, Electron, and Laser Beam Technology: Development and Use in Materials Processing*, ed. by Y. Arata, (American Society for Metals, Metals Park, OH), 1986, pp. 177-193.
4. Nello O. "Electron Beam Probing Systems – A Review", *TWI Bulletin*, 2001 May/June: 38-40.
5. Palmer T. A., Hochanadel P. W., Lachenberg K., "Quality Control of Electron Beams and Welds," *ASM Metals Handbook 11th ed.*, *Welding Fundamentals and Processes*, ASM International, pp. 548-555, 2011
6. LaFlamme G. R. and Powers D. E. 1991. Diagnostic device quantifies, defines geometric characteristics of electron beams. *Welding Journal* 70 (10): 33-40.
7. Dilthey U. and Weiser J. "Study of the electron beam "tool". Part 2: Effects on the welding result." *Schweissen. und Schneiden*, 1995, 47 (7): 558-564.
8. Dilthey U. and Weiser J. "Study of the "tool" electron beam - Part 1: Comparison between the Arata beam test and Diabeam beam measurement." *Schweissen. und Schneiden*, 1995, 47 (5): 339-345.
9. Dilthey U., in *New Developments in Advanced Welding*, ed. By N. Ahmed, (CRC Press, Boca Raton, FL), 2005, pp. 198-228.
10. Private discussions with C. Ribton and M. Nunn at The Welding Institute, Granta Park, Great Abington, UK, October, 2011.
11. Teruya A., Elmer J., and O'Brien D. "System for the Tomographic Determination of the Power Distribution in Electron Beams". *The Laser and Electron Beam in Welding, Cutting, and Surface Treatment: State-of-the-Art 1991*. 125-140; Englewood, NJ, Bakish Materials Corporation.
12. Elmer J.W., Teruya A.T., and O'Brien D.W., "Tomographic imaging of noncircular and irregular electron beam current density distribution," *Welding Journal* 1993, 72 (11): 492s-505s.
13. Elmer J.W. and Teruya A.T. Fast method for measuring power density distribution of non-circular and irregular electron beams. *Science and Technology of Welding and Joining*, 1998, **3**(2): 51-58.
14. Elmer J. W. and Teruya A. T. "An Enhanced Faraday Cup for Rapid Determination of Power Density Distribution in Electron Beams," *Welding Journal*, 2001, 80 (12): 288s-295s.
15. Elmer J. W., Hochanadel P. W., Lachenberg K., Caristan C., and Webber T., "Introduction to High Energy Electron and Laser Beam Welding," *ASM Metals Handbook 11th ed.*, *Welding Fundamentals and Processes*, ASM International, pp. 507-513, 2011.
16. Palmer T. A., and Elmer J. W., "Characterization of Electron Beams at Different Focus Settings and Work Distances in Multiple Welders Using the Enhanced Modified Faraday Cup", *Science and Technology of Welding and Joining*, 2007, 12(2), 161-174.
17. Palmer T. A., Elmer J. W., Nicklas K. D., and Mustaleski T., "Transferring Electron Beam Welding Parameters Using the Enhanced Modified Faraday Cup", *Welding Journal*, 2007, 86(12), 388s-398s.
18. Palmer T. A., and Elmer J. W., "Improving Process Control in Electron Beam Welding Using the Enhanced Modified Faraday Cup", *Journal of Manufacturing Science and Engineering*, 2008, 130(4), 041008.
19. Lachenberg K., Palmer T. A., Teruya A. T., and Elmer J. W., "Application of EB Diagnostics in Characterizing Low and High Voltage Electron Beam Welders," *Presentation at the 1st International Conference on Electron Beam Welding*, Chicago, Ill, USA, November, 2009.